



Portable Bench Scale

PBII



Portable Bench

PBII is a portable bench scale, small and easy for carrying. The large and 180° reversible display increase the convenience of usage. PB can be connected to smartphone via Bluetooth. The smartphone app provides a variety of features including weight display, statistics and wireless printer connection and more (Bluetooth option).



Easy to Carry



Large LCD with Backlight



180° Reversible Display



Bluetooth Communication (Option)



FEATURES

- 180° reversible display



- Light-weight and easy to carry
- LCD backlight for night / dark area
- Operation time
 - Rechargeable type: Over 300hours
 - Non-rechargeable type: Over 500hours
- Hold function, auto power off function
- Small and light design



OPTIONS

- Connect with smartphones by Bluetooth communication



- DC adaptor (for Dry Battery Type)
- RS-232C / USB Cable for PBII

APPLICATIONS



Parcel and Luggage Weighing

Agricultural-Fishery Products Weighing

Industrial Weighing

SPECIFICATIONS

MODEL	PBII-30kg	PBII-60kg	PBII-150kg
Capacity	15/30kg	30/60kg	60/150kg
Readability (e)	5/10g	10/20g	20/50g
External Resolution	1/3,000	1/3,000	1/3,000
Max Tare	-14.995kg	-29.99kg	-59.98kg
Display	115 x 35 [mm] / 4.5" x 1.55" 6 digit LCD		
Keys	ZERO, TARE, HOLD, POWER		
Function	Weighing Hold Function Backlight ON/OFF Control Function Print out Function		
Platter size	350 x 350 (mm)		
Power	Type 1. Dry Battery (1.5V x 4 Unit, C Size) Type 2. Pb Battery (4V, 1.3Ah) + 6V Adaptor Type 3. Li-ion Battery (3.7V, 5200mAh) + 6V Adaptor		
Operation Time	300hours (Li-ion Battery) / 500hours (Alkaline at 20°C /68°F) / 80hours (Pb Battery) / 180hours (Dry Battery)		
Operation Temperature	-10°C ~ +40°C / 14°F ~ 104°F		
Interfaces	Standard: RS-232C or USB / Option: Bluetooth		

DIMENSIONS

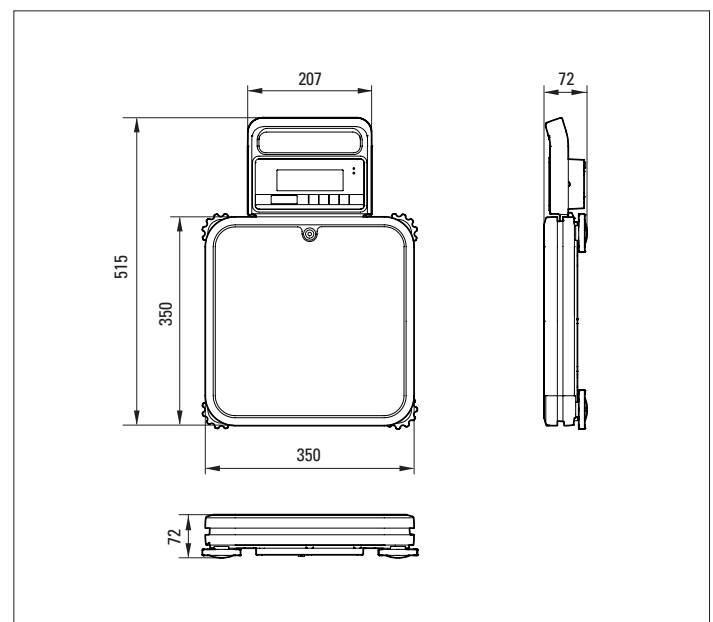

PB-Link

PB-Link is a control application for PB/PBII (Bluetooth version). Search for "PB-Link" in the Play Store or scan the QR code to download the app directly

* android  (Only Available on Android)

